

A heat transfer correlation of flow boiling in micro-finned helically coiled tube

Wenzhi Cui ^a, Longjian Li ^a, Mingdao Xin ^a, Tien-Chien Jen ^{b,*},
Qinghua Chen ^b, Quan Liao ^b

^a College of Power Engineering, Chongqing University, Chongqing 400044, China

^b Department of Mechanical Engineering, University of Wisconsin, 3200 N. Cramer Street, Milwaukee, WI 53211, USA

Received 17 July 2005; received in revised form 16 February 2006

Available online 18 April 2006

Abstract

Two main mechanisms, nucleate boiling and convective boiling, are widely accepted for in-tube flow boiling. Since the active nuclei on the heated wall are dominant for nucleate boiling and flow pattern governs the convective boiling, the heat transfer coefficient is strongly influenced by the wall heat flux, mass flux and vapor quality, respectively. In practical industrial applications, for example, the evaporators in refrigeration, forced convective evaporation is the dominant process and high heat transfer efficiency can be obtained under smaller temperature difference between wall and liquid. Therefore, it is of importance to develop a correlation of convective boiling heat transfer with a good accuracy. In this paper, a new kind of micro-finned helically coiled tube was developed and the flow boiling heat transfer characteristics were experimentally studied with R134a. Based on the analysis of the mechanisms of flow boiling, heat transfer correlations of the specific micro-finned helically coiled tubes are obtained.

© 2006 Elsevier Ltd. All rights reserved.

Keywords: Convective boiling; Heat transfer; Micro-finned; Helically coiled tube

1. Introduction

It is well known that two main mechanisms, nucleate boiling and convective boiling or forced convection evaporation, determine the heat transfer in two-phase forced flow within tube. In the practical industry applications, convective boiling is often the prevailing heat transfer mode in heat exchangers, where high heat transfer rate can be achieved at extremely small wall–liquid temperature differences. Therefore, it is of great practical significance to have well founded design recommendations, which would allow this process to be calculated with a high degree of accuracy.

In the open literature on two-phase flow and heat transfer in straight tube, extensive researches of empirical, even

semi-empirical correlations of heat transfer coefficient are continuously reported [1–7].

Klimenko [8,9] developed a “generalized” correlation for calculating the heat transfer coefficient of forced convective vaporization, which was valid for both horizontal and vertical straight tube according to the author’s conclusion. By introducing convective boiling number, N_{CB} , he divided the heat transfer of two-phase forced flow into two regions, i.e., nucleate boiling and forced convective boiling regions. The critical convective boiling number, $(N_{CB})_{cr}$, which was used to define the transition criterion between nucleate boiling and forced convective boiling regimes, is equal to 1.6×10^4 . The following correlation has been suggested for two-phase flow heat transfer:

$$Nu_{TP} = \begin{cases} Nu_b & \text{with } N_{CB} < 1.6 \times 10^4 \\ Nu_c & \text{with } N_{CB} > 1.6 \times 10^4 \end{cases} \quad (1)$$

where N_{CB} is defined as

* Corresponding author. Tel.: +1 414 229 2307; fax: +1 414 229 6958.
E-mail address: jen@cae.uwm.edu (T.-C. Jen).

Nomenclature

a	thermal diffusivity
b	Laplace constant, $[\sigma/g(\rho_l - \rho_v)]^{0.5}$
Bo	boiling number, q/Gr
D	diameter of coil, m
d	diameter of tube, m
Dn	Dean number, $Re(d/D)^{1/2}$
g	gravity acceleration, $m\ s^{-2}$
G	total mass flux, $kg\ m^{-2}\ s^{-1}$
h	heat transfer coefficient, $W\ m^{-2}\ K^{-1}$
K_p	dimensionless parameter, pb/σ
K_λ	relative heat conductivity, λ_w/λ_l
Nu	Nusselt number, hd/λ_l
p	evaporating pressure, Pa
Pe_*	modified Peclet number, $qb/r\rho_v a_1$
Pr	Prandtl number, $\mu c_p/\lambda$
q	heat flux, $W\ m^{-2}$
r	latent heat of vaporization, $J\ kg^{-1}$
Re_m	Reynolds number of mixture, $W_m d/v_l$
W_m	two-phase mixture velocity, $(G/\rho_l)[1 + x(\rho_l/\rho_v - 1)]$, $m\ s^{-1}$

x	vapor quality
X_{tt}	Lockhart–Martinelli parameter

Greek symbols

λ	heat conductivity, $W\ m^{-1}\ K^{-1}$
ν	kinematical viscosity, $m^2\ s^{-1}$
ρ	density, $kg\ m^{-3}$
σ	surface tension, $N\ m^{-1}$

Subscripts

b	boiling
c	two-phase forced convection
cal	calculated
CB	convective boiling
cr	critical
exp	experimental
l	liquid
TP	two-phase condition
v	vapor

$$N_{CB} = (rG/q)[1 + x(\rho_l/\rho_v - 1)](\rho_v/\rho_l)^{1/3} \quad (2)$$

In Eq. (1), the nucleate boiling heat transfer coefficient is calculated by following formula:

$$Nu_b = 7.4 \times 10^{-3} Pe_*^{0.6} K_p^{0.5} Pr_l^{-1/3} K_\lambda^{0.15} \quad (3)$$

and the forced convective vaporization heat transfer is given by the relation

$$Nu_c = 0.087 Re_m^{0.6} Pr_l^{1/6} (\rho_v/\rho_l)^{0.2} K_\lambda^{0.09} \quad (4)$$

Due to the high efficient heat transfer and compact volume, the helically coiled tubes are extensively used in all kinds of industries where both single- and two-phase flow can occur under specific situations. From the viewpoint of design, it is important to know the heat transfer performances in both single- and two-phase flow. Therefore, extensive studies on the flow and heat transfer in helically coiled tubes have been conducted for several decades. So far, it is well known that the secondary flow due to centrifugal force and Coriolis force in the cross-section of the tube is a significant factor affecting the flow patterns, consequently affecting heat transfer in both single- and two-phase flow. The research work for two-phase flow, however, is much insufficient, compared to that of single-phase flow.

Owhadi et al. [10] carried out a pioneering research on forced convective boiling heat transfer to water at atmospheric pressure in helically coiled tubes. Their results showed that over most of the quality region, the prevailing heat transfer mode was convection and a nucleate boiling component was present at low qualities. They found that the local average boiling heat transfer coefficient of coil

could be predicted by Chen's correlation [11] with accuracy of $\pm 15\%$ over the tested range.

Kozeki et al. [12] conducted a test on heat transfer characteristics in helically coiled tube heated by high temperature water at steam pressures of 0.5–2.1 MPa. They found two-phase forced convection occupied the most portions due to the effect of centrifugal force and secondary flow. Kozeki and most of the later researchers [13–15, 19–22] correlated their experimental results of heat transfer coefficients using Martinelli type relationship in the two-phase forced convective region.

Nariai et al. [15] conducted an investigation of thermal-hydraulic behavior in a once-through steam generator used for integrated nuclear reactor, in which the helically coiled tube was heated with liquid sodium. Their experimental results indicated that the effect of coiled tube on average heat transfer coefficients was small, Schrock–Grossman's correlation, which is commonly used for straight tube, could also be applied to coiled tube with good accuracy at the pressure lower than 3.5 MPa.

Forced convection heat transfer to high quality, two-phase water–steam mixtures in helically coiled tube has been studied by Crain and Bell [16]. Circumferential average heat transfer coefficients were correlated as a function of Lockhart–Martinelli parameter and a correction factor for Seban–McLaughlin's correlations [17] for single-phase heat transfer inside coils.

Full scale tests for coiled once-through steam generators have been studied by Campolunghi et al. [18] with subcooled water at inlet and superheated steam at outlet. They have correlated the boiling heat transfer coefficients with heat flux and operation pressure as dimensional formula.

Kubair [19] reported experimental data on heat transfer coefficients for water boiling in helical coils of curvature ratios of 0.037 and 0.056. He found from his data that the boiling heat transfer characteristics were different within the system pressure ranges. At low pressures the heat transfer coefficients could be predicted by the correlations reported by Owhadi et al. [10] and Crain and Bell [16], whereas at higher pressures some modification should be conducted. Two-phase Dean number was defined and used to correlated the full range of heat transfer data.

In Xi'an Jiaotong University, China, a research group, leading by Chen and Guo, has made extensive and systematic investigation on the multiple phase flow and heat transfer in helically coiled tube for decades. Chen and Zhou [20] believed that there was also the secondary flow in continuous phase for two-phase flow in helically coiled tubes. A significant feature of the helix was that it delayed the transition from a wetted wall to a dry wall condition compared to a straight conduit. They also correlated their test data using Lockhart–Martinelli parameter X_{tt} . Guo et al. [21] experimentally studied the forced convection boiling heat transfer characteristics in helical coiled tubes with various axial angles. They divided the convection boiling heat transfer of water–steam into three regions, i.e., nucleate boiling region, forced convection region and post-dryout region. Their results demonstrated that the system pressure affected the heat transfer coefficients and the transition boundaries between different regions. Therefore, the system pressure, expressed as the ratio to critical pressure, was incorporated in the Martinelli type correlations of heat transfer coefficient. Zhao et al. [22] proposed a new Martinelli type convective boiling heat transfer correlation, which includes a term of boiling number to account the effect of nucleate boiling mechanism.

Despite the considerable work discussed above, most of which are based on pressurized water boiling experiments, the convective boiling heat transfer of refrigerant, such as R134a, in helically coiled tubes has been investigated scarcely compared with the similar work conducted in straight tubes, and very few heat transfer coefficient correlations can be used to predict the convective boiling heat transfer process.

The present authors have developed a new kind of cross-grooved micro-finned tube, called three-dimensional micro-finned tube, from which many valuable results have been obtained. Xin et al. [23], Zhou and Xin [24] and Cui et al. [25,26] have experimentally studied the flow boiling heat transfer characteristics inside both the 3D micro-finned straight and helically coiled tube.

In this paper, the method developed by Klimenko [8] is applied and the convective boiling heat transfer correlations of smooth and micro-finned helically coiled tubes are presented based on the experimental data.

2. Experimental apparatus

Heat transfer experiments are conducted with smooth and 3D micro-finned copper helically coiled tubes, respec-

tively. The so-called 3D micro-finned tube used here is machined on the commercial single helix micro-finned tube by applying another set of grooves, which cross the original set of grooves. The geometries of the two tubes are listed in Table 1. In this experiment, the environmental-friendly refrigerant, R134a, which has replaced R12 completely and R22 partially, is used as working fluid. The test conditions are listed in Table 2.

The experimental scheme and corresponding apparatus used in this study are shown in Fig. 1. In this experiments, the test helically coiled tube is vertically positioned, i.e. refrigerant enters the test section at the lower inlet and flows up helically until it exits from the upper outlet, and heated by an electrical flat band heater, which is closely placed and tightly wrapped around the outer surface of the testing tubes. To decrease the heat loss to the environment, a thermally insulating material (glass fiber mat), whose thermal conductivity is 0.043 W/(m K), is wrapped on the outer surface of the helical testing tubes with a thickness of 30.0 mm. Before each experiment, an energy balance test is conducted and the result demonstrated that the heat loss to the environment is within 5.0% on the condition that ambient temperature is below 35.0 °C. The effect of heat loss has been accounted for all the data obtained from the experiments.

Since in this experiment the temperature is a key parameter that needs to be measured accurately, calibrated thermocouples mounted on the outer surface of the helical testing tubes' wall are used as temperature sensors. On the other hand, a differential pressure transducer with accuracy of $\pm 0.5\%$ FS (full scale), operating over the range of 0.0–20.0 kPa, is used to measure the two-phase flow pressure drop and a float flow meter with accuracy of $\pm 2.5\%$

Table 1
Test tube geometries

	Smooth tube	Micro-finned tube
Outer diameter, mm	12	12.7
Inner diameter, mm	10	11.2
Number of fins	–	60
Circumferential fin pitch, mm	–	0.59
Axial fin pitch, mm	–	1.0
Fin height, mm	–	0.25/0.3 ^a
Fin helix angle [deg]	–	18/88.5 ^a
Coil diameter, mm	180	185
Coil pitch, mm	50	50

^a The two entries refer to circumferential and axial fin parameters, respectively.

Table 2
The range of test conditions

Parameters	Smooth tube	Micro-finned tube
Evaporating pressure, MPa	0.49–0.58	0.50–0.58
Mass flux, kg/(m ² s)	70–380	65–320
Heat flux, kW/m ²	2.0–20.0	2.0–21.8
Vapor quality, %	0.05–95	0.05–92

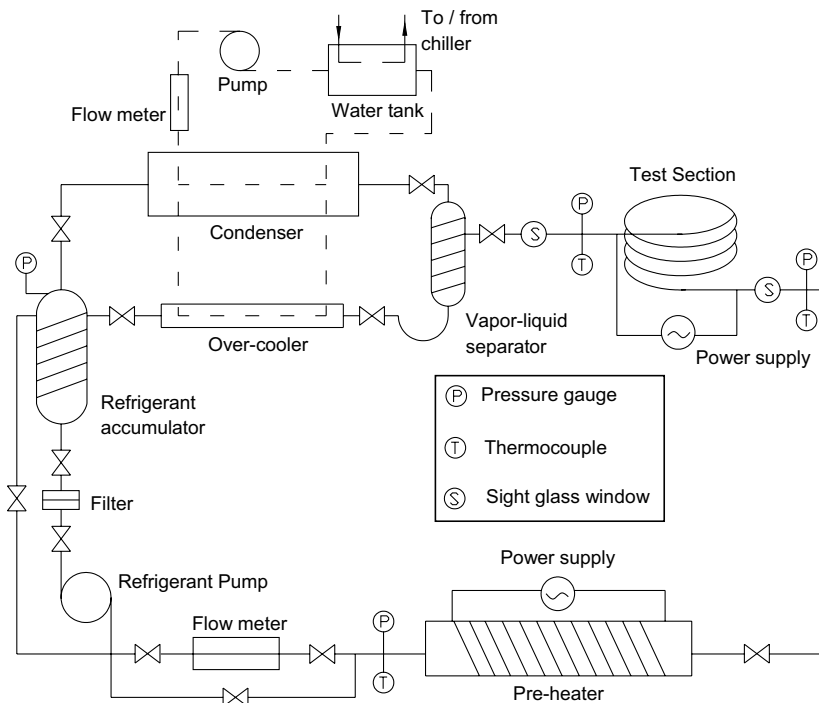

Fig. 1. Schematic diagram of the test loop.

reading value is applied to measure the flow rate of sub-cooled liquid refrigerant before the pre-heater. The saturation pressures at the inlet and outlet of the test section are measured with exact pressure gauges whose accuracy is up to $\pm 0.15\%$ FS (1600 kPa) and the mean value of these two pressures is used to determine the saturation temperature and other corresponding physical properties of the refrigerant, including liquid and vapor phases.

The vapor quality entering the test section is controlled by a horizontal electric pre-heater. A thermistor and a pressure transducer, located at the pre-heater inlet, establish the thermodynamic state of the liquid entering the pre-heater. This measurement, along with the electric energy supplied in the pre-heater, is used to determine the R134a vapor quality at the inlet of test section.

The detailed description of the experimental apparatus and uncertainties analysis is also referred to Li et al. [27].

3. Experimental results

Fig. 2 shows the local flow boiling heat transfer coefficients against vapor quality with different mass flow rates for micro-finned helically coiled tube. As shown in Fig. 2(a), while keeping wall heat flux constant (here $q = 2.0 \text{ kW/m}^2$), the heat transfer coefficients consistently increase with the improving of the vapor qualities. The raising of mass flux also results in the increases of heat transfer coefficients for all the qualities. It is well known that, when the quality is low, stratified-wavy flow dominates the flow pattern, while in high quality region, annular or semi-annular flow becomes significant. Therefore, the prevailing flow pattern strongly affects the heat transfer

performance. Moreover, it also can be seen in Fig. 1(a), the coefficient curves stand closely in low quality region and gradually space apart in high quality region.

In Fig. 2(b) mass flux is kept constant and heat transfer coefficients monotonously increase against vapor qualities at lower wall heat flux. When heat flux is further increased, however, along with the increase of vapor quality, the heat transfer coefficients increase first, and then decrease slightly. This can be explained that the upper part of the inside surface of the tube becomes partial dryout when vapor quality is at a certain value (here it is about 0.7–0.8), which in turns, lowers the circumferential average heat transfer coefficient.

As shown in Fig. 2(a) and (b), the dependence of the heat transfer coefficient on heat flux and mass flux is different in the experimental range of vapor quality. In lower vapor quality region, heat transfer coefficient depends more on the heat flux and the mass flux shows a relatively weak effect on it. Meanwhile, the reverse is true in higher vapor quality region. This indicates the two mechanisms, i.e., the nucleation mechanism and the convection mechanism, in two-phase flow heat transfer play different roles in different flow regimes. And both of the two mechanisms have the same significance to forced convective boiling heat transfer in helically coiled tube.

4. Transition from nucleate boiling to forced convection vaporization

In Ref. [8], Klimenko introduced a criterion to determine what type of heat transfer, nucleate boiling or convective boiling, is dominant in two-phase flow regime. He

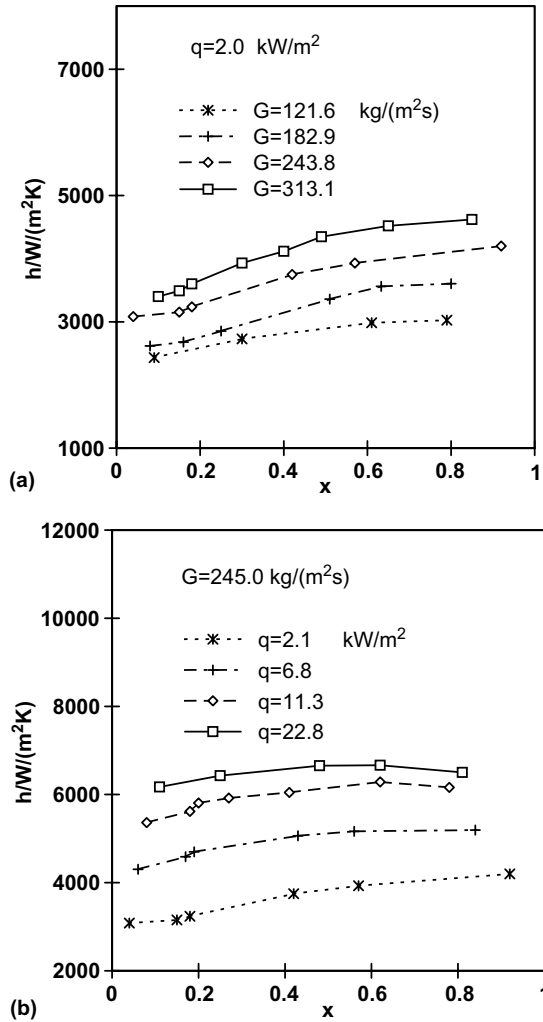

Fig. 2. Local heat transfer coefficients against vapor quality.

proposed that the relative role of various heat transfer mechanisms could be determined by the ratio of corresponding heat transfer coefficients and the convective boiling number, defined by Eq. (2). Based on the experimental data set, the critical convective boiling number, which equals to 1.6×10^4 , was recommended as the criterion between nucleate boiling and forced convection vaporization regimes.

The convective boiling heat transfer formula used in Ref. [8] was only valid for straight tube. In order to include the specific characteristics of helically coiled tube, a new heat transfer formula should be developed. It is an well-established fact that the only parameter, which determines the comparability of flow, and hence heat transfer, in helically coiled tube, is the Dean number, which is defined as $Dn = Re(d/D)^{1/2}$. For two-phase flow, the Reynolds number should use two-phase mixture Reynolds number, Re_m , which is defined by substituting the velocity with two-phase mixture velocity, W_m , as

$$Re_m = \frac{W_m d}{\nu_1} = \frac{Gd}{\mu_1} \left[1 + x \left(\frac{\rho_1}{\rho_v} - 1 \right) \right] \quad (5)$$

After introducing the two-phase Dean number, Dn_m , into the correlation, the convective vaporization heat transfer coefficients of the smooth and micro-finned helically coiled tube are presented as follows:

For micro-finned tube:

$$Nu_c = 0.087 Re_m^{0.6} Pr_1^{1/6} (\rho_v/\rho_l)^{0.2} K_\lambda^{0.09} Dn_m^{0.1} \quad (6)$$

For smooth tube:

$$Nu_c = 0.087 Re_m^{0.6} Pr_1^{1/6} (\rho_v/\rho_l)^{0.2} K_\lambda^{0.09} Dn_m^{0.06} \quad (7)$$

The powers 0.1 and 0.06 of Dn_m in Eqs. (6) and (7) are obtained from the regression of experimental data of micro-finned and smooth helically coiled tubes, respectively.

Based on Eqs. (6) and (7), the experimental data, including micro-finned and smooth helically coiled tube, are processed in the form of $Nu/Nu_c = f(N_{CB})$ and presented in Fig. 3(a) and (b), respectively. It can be seen from these figures that there are distinct changes from one heat transfer mode to another, which is similar to that in the straight tube by Klimenko [8]. When $N_{CB} > (N_{CB})_{cr}$, the dominant heat transfer mode is the convective boiling, however, the dominant heat transfer mode is nucleate boiling when

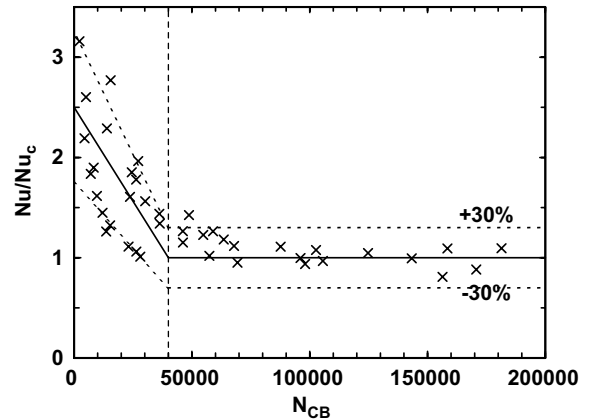

(a) Smooth tube

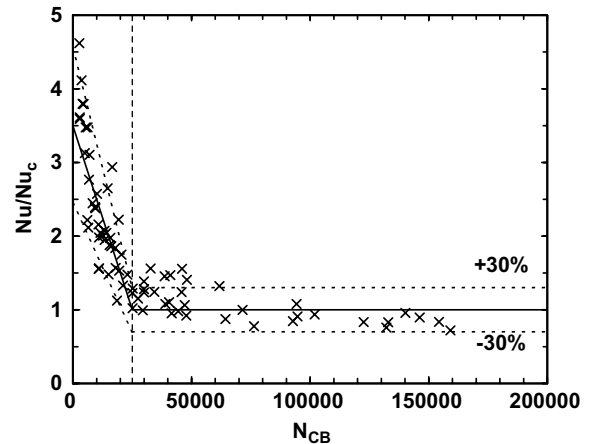

(b) Micro-finned tube

Fig. 3. Transition from nucleate boiling to forced convection vaporization.

$N_{CB} < (N_{CB})_{cr}$. On the other hand, the value of critical number N_{CB} is different with that proposed by Ref. [8] in straight tube. The corresponding values for smooth and micro-finned helically coiled tubes are 40,000 and 25,000, respectively.

5. Development of correlation

Chen’s correlation [11] widely used to calculate flow boiling heat transfer coefficient in straight tube is one of the most famous correlations that based on the mechanism of nucleate and convective dominated heat transfer. Owahdi et al. [10] indicated that Chen’s correlation could also be applied to helically coiled tube with acceptable agreement. All the present experimental data of smooth and micro-finned helically coiled tubes are compared with Chen’s correlation as shown in Fig. 4(a) and (b). Obviously, Chen’s correlation underestimates all the data and there is considerable scatter in the plots, which is much evident for micro-finned tube. This indicates that Chen’s cor-

relation, which is quite successful to predict two-phase heat transfer in straight tube, cannot properly predict the augmentation heat transfer of helically coiled tube due to the special geometric construction under the present test conditions. Furthermore, the heat transfer enhancement own to the micro-finned heat transfer surface is also cannot be predicted by the original Chen’s correlation unless the suppression factor, S , and enhancement factor, F , in that correlation are properly modified.

For correlating two-phase heat transfer coefficient in helically coiled tube, Martinelli type correlation is another popular method, which is used by most researchers in this field [10,12–16,19–22], some of them adding a nucleate boiling term, such as boiling number, Bo , to combine the effect of nucleate boiling mechanism [15,22]. Kozeki et al.’s [12] and Guo’s [22] correlations are chosen to compare with the present heat transfer data, as shown in Fig. 5(a) and (b) for smooth and micro-finned helically coiled tube, respectively. Kozeki’s correlation and Guo’s correlation are expressed as

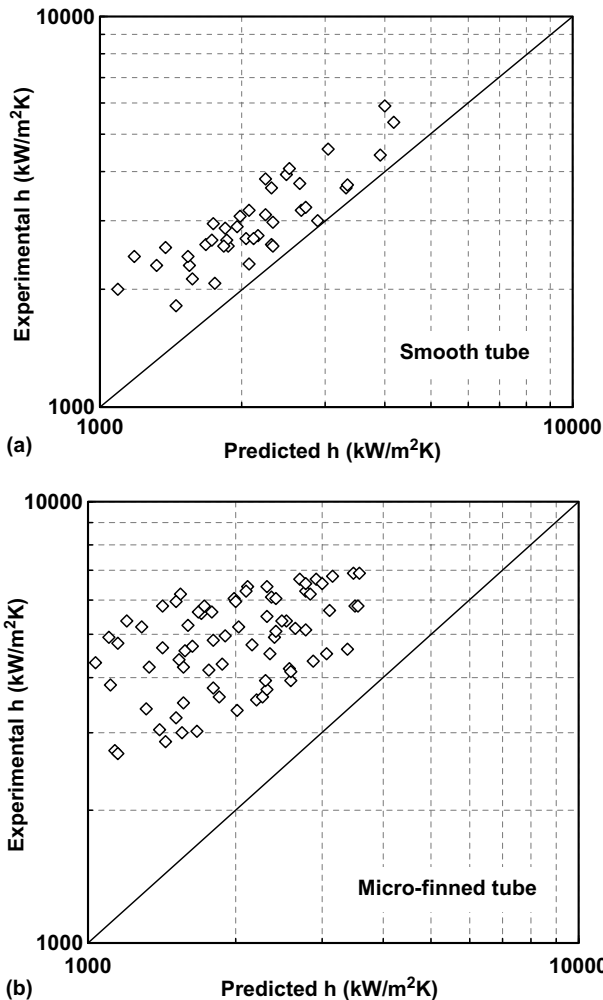

Fig. 4. Comparison of experimental heat transfer data with Chen’s correlation.

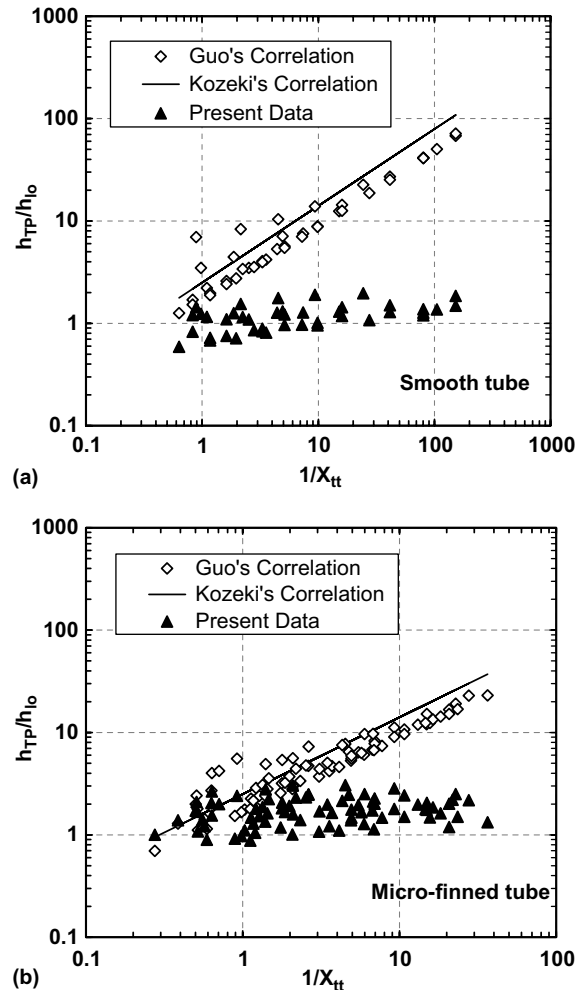

Fig. 5. Comparison of experimental heat transfer data with Kozeki’s correlation and Guo’s correlation.

$$\frac{h_{TP}}{h_{lo}} = 2.5 \left(\frac{1}{X_{tt}} \right)^{0.75} \quad (8)$$

and

$$\frac{h_{TP}}{h_{lo}} = 1.6 \left(\frac{1}{X_{tt}} \right)^{0.74} + 183000Bo^{1.46} \quad (9)$$

respectively. Again, these two correlations cannot predict the present experimental results very well. In these correlations the heat transfer coefficients are expressed as the ratio of two-phase heat transfer coefficient to the single-phase heat transfer coefficient at the same mass flux when the fluid is completely liquid. Hence, the comparison indicates that the correlations based on water–steam two-phase flow overestimate the heat transfer enhancement of two-phase heat transfer to single-phase heat transfer for refrigerant flow boiling especially in higher X_{tt} region.

It is clear from the above discussion that none of the existing correlations can well predict the convective boiling heat transfer in smooth or micro-finned helically coiled of refrigerant R134a, despite the correlations proposed above agree well with experimental results of high or normal pressure water–steam two-phase flow. Therefore, a new correlation should be developed to predict the flow boiling heat transfer of refrigerant inside helically coiled tube. Following Klimenko’s methods, the heat transfer characteristics have been analyzed above. It can be found that there exists some relationship between convective boiling number, N_{CB} , and the ratio of two-phase heat transfer coefficient and single-phase heat transfer coefficient, h_{TP}/h_{lo} . Based on this fact, the following will develop the new flow boiling heat transfer correlation for refrigerant inside helically coiled tube. Because the present data of smooth helically coiled tube are insufficient to be correlated, the flow boiling heat transfer correlation is only developed for micro-finned helically coiled tube (shown in Fig. 6).

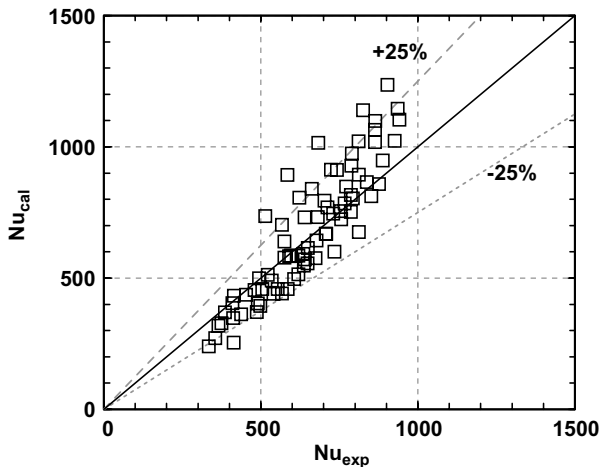

Fig. 6. Comparison of experimental flow boiling heat transfer results with correlation.

The experimental data of micro-finned helically coiled tube through the whole range of N_{CB} can be correlated by using an exponential function with following form:

$$Nu/Nu_c = 100.7N_{CB}^{-0.414} \quad (10)$$

where N_{CB} and Nu_c are defined in Eqs. (2) and (6), respectively. Substitute Nu_c with Eq. (6), it yields

$$Nu = 8.76Re_m^{0.6}Pr_1^{1/6}(\rho_v/\rho_l)^{0.2}K_z^{0.09}Dn^{0.1}N_{CB}^{-0.414} \quad (11)$$

All of the data in this paper are compared with the above correlation as shown in Fig. 3.

The mean absolute deviation is given by

$$\bar{D} = \frac{1}{n} \sum_{i=1}^n \frac{|Nu_{exp} - Nu_{cal}|}{Nu_{cal}} \quad (12)$$

where n is the number of experimental points. Finally, it is found that the mean absolute deviation for the proposed correlation is 13.8%.

6. Conclusions

Two-phase forced flow heat transfer experiments are conducted in smooth and micro-finned helically coiled copper tubes. Two main mechanisms, i.e., nucleate boiling and convective boiling (or forced convective vaporization), take part in the heat transfer in two-phase forced flow. The change of local heat transfer coefficients against vapor quality indicates that the relative effects of these two mechanisms are different in corresponding regions. And both the two mechanisms have the same significance to forced convective boiling heat transfer in helically coiled tube.

The method used by Klimenko [8] is applied to process the experimental data with some corresponding modifications that includes the curvature effect of helically coiled tube in the calculation of convective boiling heat transfer coefficient by introducing two-phase Dean number in Eqs. (6) and (7). Distinct boundary between nucleate boiling and convective boiling is also found in the test data of helically coiled tubes. The transition values between nucleate boiling and convective boiling for micro-finned helically coiled tubes and smooth tubes are quite different with that suggested by Klimenko in straight tube.

The comparison of the test results with some of the representative heat transfer correlations indicates that none of the existing correlations can correlated the refrigerant flow boiling inside smooth or micro-finned helically coiled tubes with acceptable deviation. Based on the experimental data reduction, a new heat transfer correlation of forced flow boiling is obtained and it has a mean absolute deviation of 13.8%.

Acknowledgments

The authors, Mingdao Xin, Wenzhi Cui and Longjian Li, acknowledge the financial support of this work by China National Key Fundamental Research (No.

G2000026305) and the Special Research Foundation for University Doctoral Subject of China Ministry of Education (No. 1999061101). Dr. Tien-Chien Jen, Mr. Qinghua Chen and Mr. Quan Liao would also like to acknowledge the partial financial support from NSF (US) GOALI DMII-9908324.

References

- [1] M.M. Shah, A new correlation for heat transfer during boiling flow through pipes, *ASHRAE Trans.* 82 (2) (1976) 66–86.
- [2] R.W. Bjorge, G.R. Hall, W.M. Rohsenow, Correlation of forced convection boiling heat transfer data, *Int. J. Heat Mass Transfer* 25 (6) (1982) 753–757.
- [3] K.E. Gungor, R.H.S. Winterton, A general correlation for flow boiling in tubes and annuli, *Int. J. Heat Mass Transfer* 29 (3) (1986) 351–358.
- [4] S.G. Kandlikar, A general correlation for saturated two-phase flow boiling heat transfer inside horizontal and vertical tubes, *Trans. ASME, J. Heat Transfer* 112 (1) (1990) 219–228.
- [5] Z. Liu, R.H.S. Winterton, A general correlation for saturated and subcooled flow boiling in tubes and annuli, based on a nucleate pool boiling equation, *Int. J. Heat Mass Transfer* 34 (11) (1991) 2759–2766.
- [6] D. Steiner, J. Taborek, Flow boiling heat transfer in vertical tubes correlated by an asymptotic model, *Heat Transfer Eng.* 13 (2) (1992) 43–69.
- [7] N. Kattan, J.R. Thome, D. Favrat, Flow boiling in horizontal tubes: Part 3—development of new heat transfer model based on flow pattern, *Trans. ASME, J. Heat Transfer* 120 (1998) 156–165.
- [8] V.V. Klimenko, A generalized correlation for two-phase forced flow heat transfer, *Int. J. Heat Mass Transfer* 31 (3) (1988) 541–552.
- [9] V.V. Klimenko, A generalized correlation for two-phase forced flow heat transfer—second assessment, *Int. J. Heat Mass Transfer* 33 (10) (1990) 2073–2088.
- [10] A. Owhadi, K.J. Bell, B. Crain Jr., Forced convection boiling inside helically coiled tubes, *Int. J. Heat Mass Transfer* 11 (1968) 1179–1193.
- [11] J.C. Chen, A correlation for boiling heat transfer to saturated fluids in convective flow, *I & EC Process Des. Develop.* 5 (3) (1966) 322–329.
- [12] M. Kozeki, H. Nariyai, T. Furukawa, K. Kurosu, A study of helically coiled tube once-through steam generator, *Bull. JSME* 13 (66) (1970) 1485–1494.
- [13] L.J. Guo, X.J. Chen, M.Y. Zhang, Research on the forced convective boiling heat transfer characteristics of steam water two-phase flow in horizontal helically coiled tubes, *J. Xi'an Jiaotong Univ.* 28 (5) (1994) 120–124.
- [14] B.F. Bai, L.J. Guo, Study on convective boiling heat transfer in horizontal helically coiled tubes, *Chin. J. Nucl. Sci. Eng.* 17 (4) (1997) 302–308 (in Chinese).
- [15] H. Nariyai, M. Kobayashi, T. Matsuoka, Friction pressure drop and heat transfer coefficient of two-phase flow in helically coiled tube once-through steam generator for integrated type marine water reactor, *J. Nucl. Sci. Technol.* 109 (11) (1982) 936–947.
- [16] B. Crain, K.J. Bell, Forced convection heat transfer to a two phase mixture of water and steam in a helical coil, *AIChE Symp. Ser.* 69 (1973) 30–36.
- [17] R.A. Seban, E.F. Mclaughlin, Heat transfer in tube coils with laminar and turbulent flow, *Int. J. Heat Mass Transfer* 6 (5) (1963) 387–395.
- [18] F. Campolunghi et al., Full scale tests and thermal design for coiled once-through heat exchangers, *AIChE Symp. Ser.* 73 (1977) 215–222.
- [19] V.G. Kubair, Heat transfer to multiphase flow in coiled pipes, heat transfer 1986, in: C.L. Tien et al. (Ed.), *Proc. 8th Int. Heat Transfer Conf.*, San Francisco, USA, vol. 5, 1986, pp. 2355–2360.
- [20] X.-J. Chen, F.-D. Zhou, Forced convective boiling and post-dryout heat transfer in helical coiled tubes, heat transfer 1986, in: C.L. Tien et al. (Ed.), *Proc. 8th IHTC*, San Francisco, USA, vol. 5, 1986, pp. 2221–2226.
- [21] L.J. Guo, X.J. Chen, et al., Forced convection boiling heat transfer and dryout characteristics in helical coiled tubes with various axial angles, heat transfer 1998, in: *Proc. 11th IHTC*, Kyongju, Korea, vol. 2, 1998, pp. 261–266.
- [22] L. Zhao, L.J. Guo, et al., Convective boiling heat transfer and two-phase flow characteristics inside a small horizontal helically coiled tubing once-through steam generator, *Int. J. Heat Mass Transfer* 46 (2003) 4779–4788.
- [23] M.D. Xin, J. Zhou, et al., Boiling in the horizontal tubes with three-dimensional inner micro-finned, *Chin. J. Eng. Thermophys.* 22 (1) (2001) 95–97 (in Chinese).
- [24] J. Zhou, M.D. Xin, Boiling heat transfer of partial annular flow in a horizontal three-dimensional micro-finned tube, *J. Therm. Sci. Technol.* 1 (1) (2002) 11–14 (in Chinese).
- [25] W.Z. Cui, Q. Liao, M.D. Xin, Flow boiling heat transfer of R134a in a helical coiled tube, *J. Chongqing University* 24 (4) (2001) 118–121 (in Chinese).
- [26] W.Z. Cui, M.D. Xin, Q. Liao, Flow boiling heat transfer and flow patterns in three-dimensional micro-fin helically coiled tube, *Chin. J. Eng. Thermophys.* 24 (3) (2003) 451–454 (in Chinese).
- [27] L.J. Li, W.Z. Cui, et al., Heat transfer augmentation in 3D inner finned helical tube, *Int. J. Heat Mass Transfer* 48 (10) (2005) 1916–1925.